



UNIVERSAL VERSACAP IMPACT CRUSHER

McLanahan's Universal VersaCap Impact Crusher is designed with both safety and profitability in mind. Its low profile design is excellent for portability. Each Universal VersaCap is engineered for high productivity, as well as low maintenance and downtime to increase your profitability. This highly versatile design is perfect for a broad scope of applications, including C&D recycling, aggregate, and mining applications.

Improved Maintenance And Wear Life

McLanahan's Universal VersaCap is equipped with large access doors for inspection and maintenance on the sides, back and top of the impactor, providing unmatched accessibility. The primary impact curtain is a 'monoblock' consisting of a massive, reversible manganese casting with replaceable wear edges for extended wear life and a maintainable gap setting. The secondary impact curtain is a heavy-duty weldment fully-lined in the impact zone and gravity-hung from a pivot pin at the feed opening, meaning there is no need for a spring-bridge assembly to hold the gap setting. Additionally, Universal VersaCap Impact Crushers offer an optional third curtain assembly with a fully-lined and spring loaded hydraulic-shim adjustment. Curtains automatically retract for relief from uncrushable tramp iron, immediately resetting to the original gap setting. Wrench-free curtain adjustment is standard with simple hydraulic-shim adjustment on all curtains. Shims provide a visual indicator outside the impactor for improved maintenance planning. Multiple levels of automation are available, including "Unimation", a PLC system with touchscreen control for individual curtain gap settings, as well as maintaining the geometry and adjusting all curtains at once for better hammer wear.

Designed For Optimal Production

Universal VersaCap Impact Crushers feature heavy, reinforced plate steel housing, designed to withstand heavy impact. Standard two-curtain designs can be field modified to add an optional third curtain, and rotor assemblies are available in three or four bar designs to meet site requirements. Universal VersaCap Impact Crushers are engineered with huge access doors for quick and thorough inspections, and with a curtain adjustment procedure that's measured in minutes, not hours. This helps minimize downtime, while keeping the crusher operating at optimum capacity. They are also designed with more curtain retraction than competitive designs, providing increased tramp iron protection. The impact hammers (blowbars) are designed with a protruding leading edge for improved gradation control through the life of the hammers. Depending on the application requirements, hammers are available in standard or heavy weight, as well as a variety of alloys, to optimize wear cost. The Universal VersaCap Impact Crusher provides increased productivity for longer intervals between scheduled maintenance.

Optional Adjust-On-The-Fly Technology And Automation

Universal VersaCap Impact Crushers are available with optional components that provide adjust-on-the-fly technology. This allows producers to hydraulically adjust the curtains with finger-tip lever control while the crusher is under full load. Safety shims protect the rotor and adjustment is based on visual observation or downstream indicators. McLanahan also offers the ultimate in automation. The Unimation program offers PLC control to ensure precise gap settings and a patent-pending, hands-free calibration capability that can be completely accomplished without opening the crusher.

UNIVERSAL VERSACAP IMPACT CRUSHER

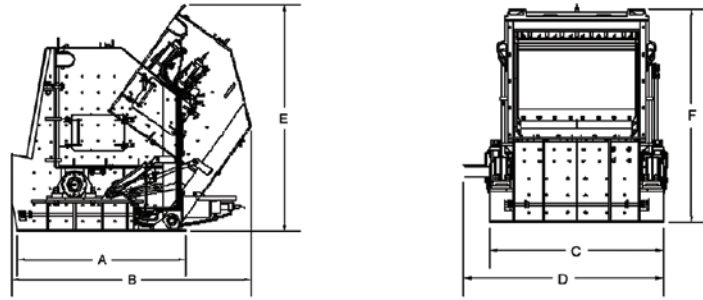

Dimensions

		VersaCap 400P	VersaCap 500P	VersaCap 600P
A = Length at Base	in mm	93.75 2,380	93.75 2,380	93.75 2,380
B = Length at Hood Opening	in mm	133 3,380	133 3,380	133 3,380
C = Width at Base	in mm	72.5 1,840	87.5 2,225	102.5 2,605
D = Width at Shaft	in mm	86 2,185	101 2,565	116 2,950
E = Height - Hood Open	in mm	127 3,225	127 3,225	127 3,225
F = Height - Hood Closed	in mm	109 2,770	109 2,770	109 2,770

Specifications

		VersaCap 400P	VersaCap 500P	VersaCap 600P
Capacity @ - 6" (Estimated Average)	STPH	400	500	600
Feed Opening (Width x Height)	in mm	46 x 42 1,170 x 1,067	61 x 42 1,550 x 1,067	76 x 42 1,930 x 1,067
Maximum Feed Size	in mm	40 1,016	40 1,016	40 1,016
Discharge Opening (Width x Length)	in mm	46 x 72 1,168 x 1,829	61 x 72 1,549 x 1,829	76 x 72 1,930 x 1,829
Rotor Size (Diameter x Width)	in mm	51 x 45 1,295 x 1,143	51 x 60 1,295 x 1,524	51 x 75 1,295 x 1,905
Crusher Weight*	lbs. kg	38,250 17,350	44,800 20,320	51,350 23,290
Rotor Speed	RPM	350-600	350-600	350-600
Horsepower Without Third Curtain	HP	300	400	500
Side Liners (Wear Thickness)	in mm	1.0 AR 25.4	1.0 AR 25.4	1.0 AR 25.4
Standard 5" Hammers (Primary) - Weight - Rows - Material (Model 600 Uses A 30" & 45" Hammer)	lbs./kg	996/452 3 x 1 Alloy, Steel or Manganese	664/301 3 x 2 Alloy, Steel or Manganese	664/301 996/452 3 x 2 Alloy, Steel or Manganese
Standard 4 1/4" Hammers (Recycle) - Weight - Rows - Material (Model 600 Uses A 30" & 45" Hammer)	lbs./kg	908/412 3 x 1 Alloy, Steel or Manganese	605/275 3 x 2 Alloy, Steel or Manganese	605/275 908/412 3 x 2 Alloy, Steel or Manganese
Optional Third Curtain	lbs. kg	2,960 1,343	3,450 1,565	3,940 1,787
Standard Monoblock Primary Curtain	lbs. kg	5,050 2,390	6,925 3,140	8,800 3,990
Optional Fabricated Primary Curtain	lbs. kg	4,500 2,040	6,000 2,720	7,500 3,400

Additional Options

	VersaCap 400P	VersaCap 500P	VersaCap 600P
Feed Chute		Primary Feed Chute With Or Without Hydraulic Feed Plate	
Curtain Adjustment		Hydraulic Adjust With Touch Screen Controls	
Rotor		4-Bar	

Note: Consult factory for proper hammer selection and application questions.

*Weight consisting of 2 Curtain, Monoblock, 3-Bar Rotor w/ 5" Hammers